

6"-150# R.F.S.O.
 FLG. W/SCH 80
 SA-106-B
 PIPE x 7 5/8"LG.
 (2) PLC'S

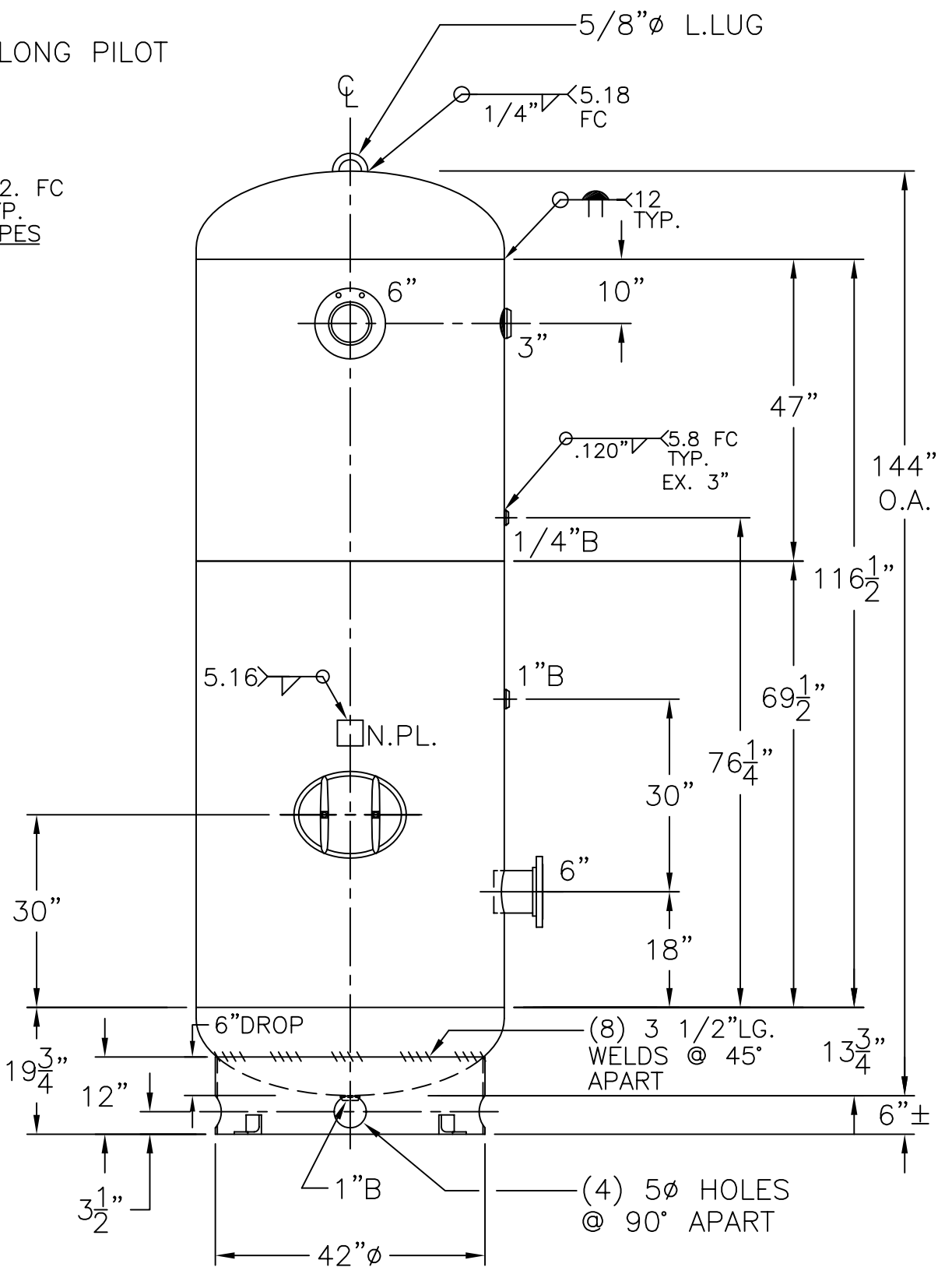

NOTE: 1) HYDRO @ 215 PSIG. MIN.

SHELL / HEADS		.218" SA-455 2:1 S.E. (.218"MIN.) JOGGLE	
M.A.W.P.	165 PSIG. @ 400 °F		
M.D.M.T.	-20 °F @ 165 PSIG.		
ASME. SECTION VIII	DIV. 1, 2010 ADD 2010		
X-RAY:	RT-4 SPOT L.S. ONLY		
GALLONS:	1060	WT.	1879 LBS.
SERIAL NO.			
N.B.			
INSIDE: UNPAINTED		48-VM-1060-R	
OUTSIDE: PRIME		REV.	8-8-11
FOR: HANSON STANDARD		DATE:	10-27-98
VERT. AIR TANK			
UW-21(b)			
SCALE: 1/2"=12"			
BY: J.G.			
CAD "B" SIZE UNDER "STD"-SERIES			
ROY E. HANSON JR. MFG.			
1600 E. WASHINGTON BLVD.			
LOS ANGELES, CA 90021			

