

VIEW W/OUT SUPT'S

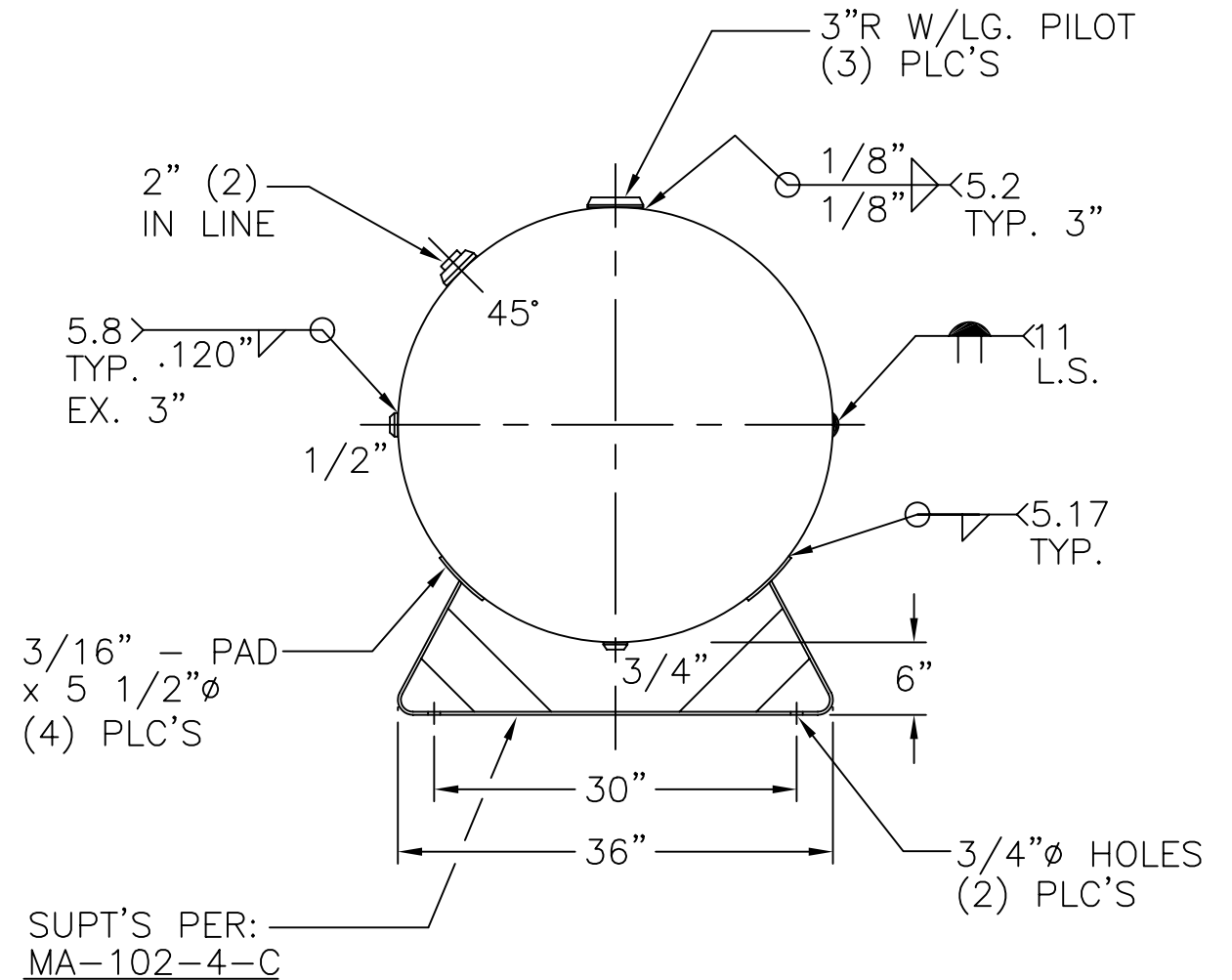

SUPT'S PER:  
MA-102-4-C

NOTE: 1) HYDRO @ 260 PSIG. MIN.

HEADS	.210" SA-455 2:1 S.E.	36-HA-300-W	REV. 11-18-02
	JOGGLE - 210" OFFSET		DATE: 10-21-92
SHELL	.200" SA-455	FOR: HANSON STANDARD	
		HORIZ. AIR TANK	
		INSIDE: UNPAINTED	
	M.A.W.P. 200 PSIG. @ 400 °F	OUTSIDE: PRIME	
	M.D.M.T. -20 °F @ 200 PSIG.	CAD-"B" SIZE UNDER "STD"-SERIES	
	ASME SECTION VIII DIV. 1, 2001	BY: J.G.	SCALE: 3/4"=12"
	X-RAY: RT-4 SPOT L.S. ONLY	<b>ROY E. HANSON JR. MFG.</b>	
	GALLONS: 300 WT. 586 LBS.	1924 COMPTON AVE.	
	SERIAL NO.	LOS ANGELES, CA 90011	