

VIEW W/OUT SUPT'S

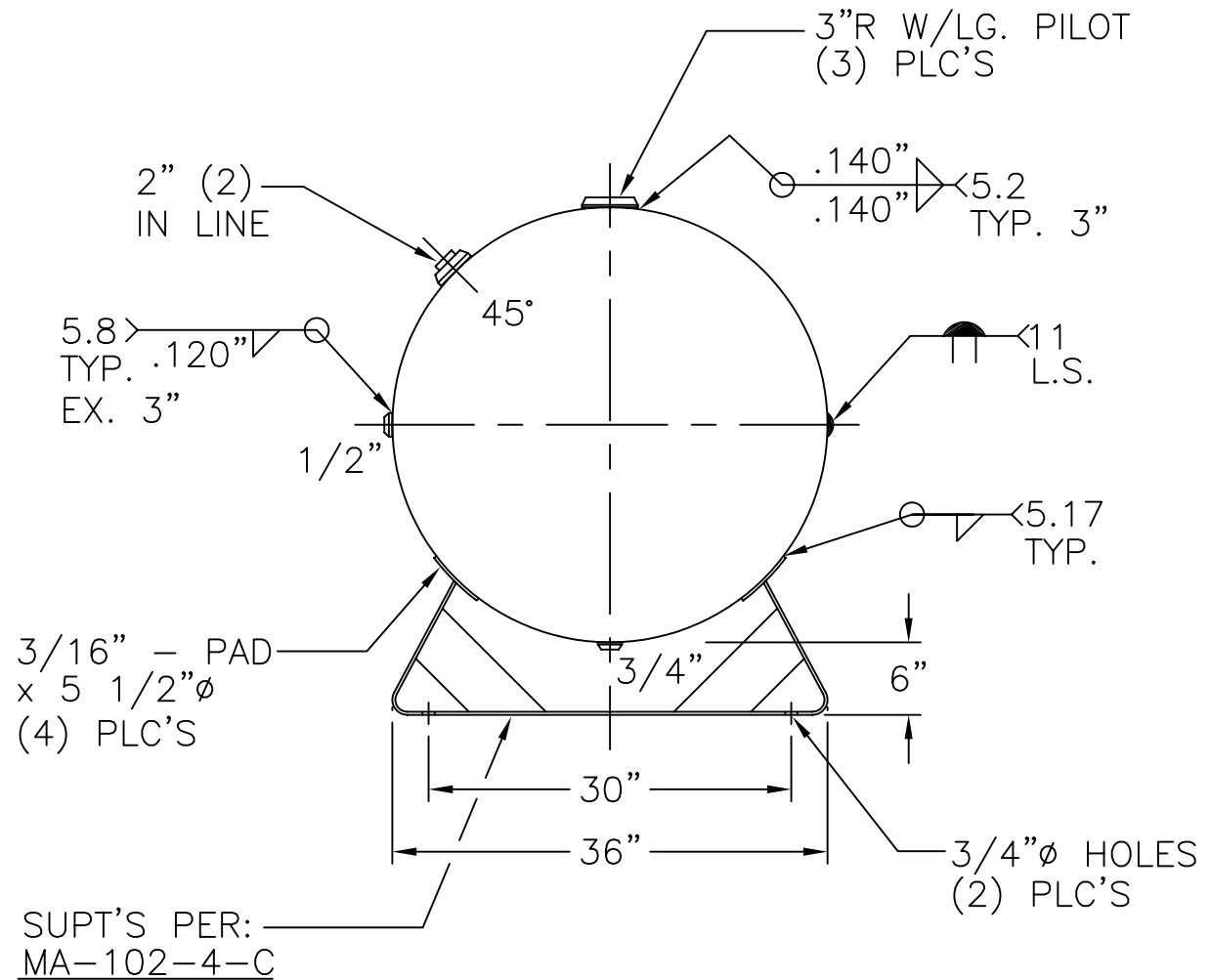

NOTE: 1) HYDRO @ 262 PSIG. MIN.

HEADS	.182" SA-455 2:1 S.E.	36-HA-400-W	REV. 1-30-07
	JOGGLE		DATE: 10-5-81
SHELL	.209 OFFSET	FOR: HANSON STANDARD	
	.200 SA-455	HORIZ. AIR TANK	
M.A.W.P. 200 PSIG. @ 400 °F		INSIDE: UNPAINTED	
M.D.M.T. -20 °F @ 200 PSIG.		OUTSIDE: PRIME	
ASME SECTION VIII DIV. 1, 2004 ADD 2006		CAD-"B" SIZE UNDER "STD"-SERIES	
X-RAY: RT-4 SPOT L.S. & G.S.		BY: J.G.	SCALE: 3/4"=12"
GALLONS: 400 WT. 710 LBS.		<b>ROY E. HANSON JR. MFG.</b>	
SERIAL NO.		1600 E. WASHINGTON BLVD. LOS ANGELES, CA 90021	