

2" B W/C.I. PLUG
INSP. OPENING
(2) PLC'S

VIEW W/OUT SUPT'S

SUPT'S PER: MA-102-4-C
NO PADS

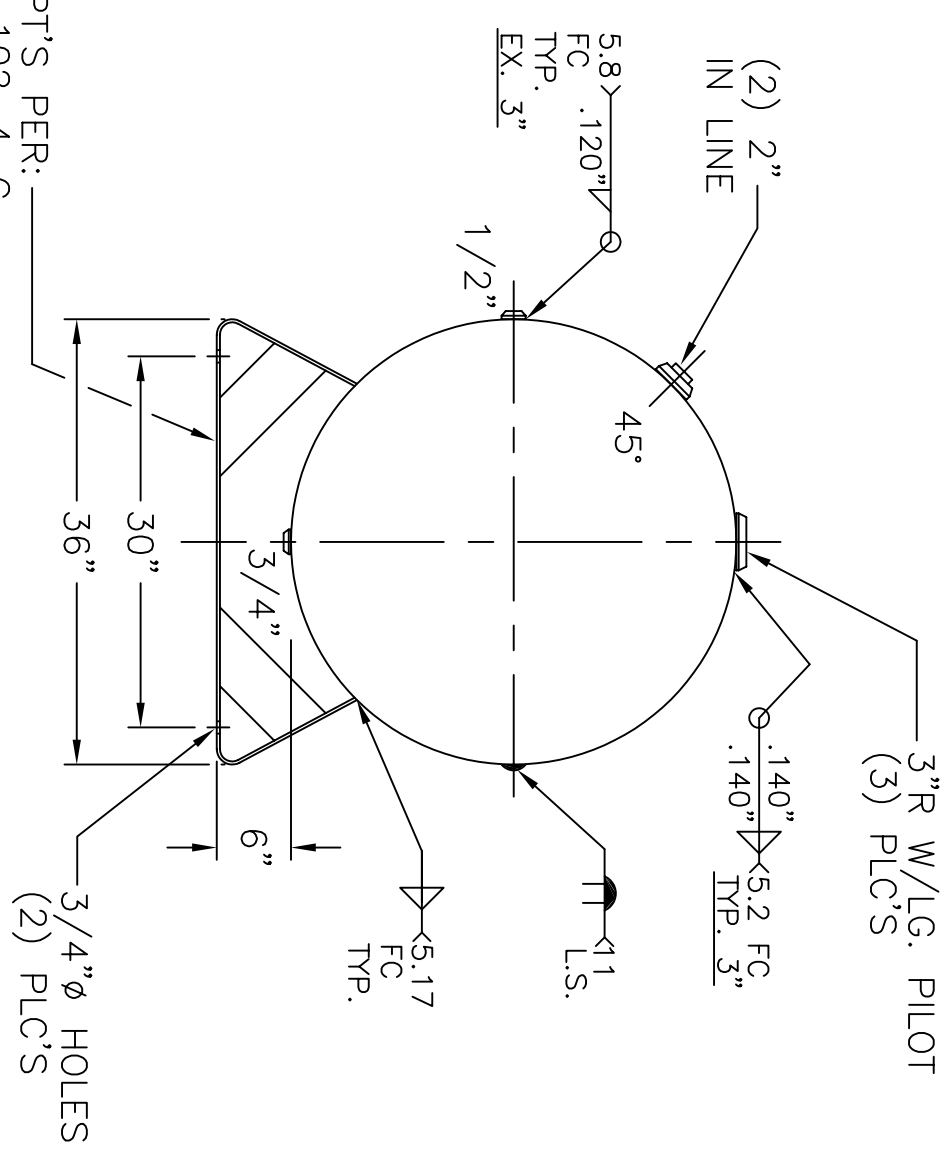

NOTE: 1) HYDRO @ 390 PSIG. MIN.

SHELL / HEADS		.3125" SA-455 2:1 S.E. (.293" MIN.) TRIM	
M.A.W.P.		300 PSIG. @ 400 °F	
M.D.M.T.		-20 °F @ 300 PSIG.	
ASME SECTION VIII		DIV. 1, 2007 ADD 2008	
X-RAY:		RT-4 SPOT L.S. ONLY	
GALLONS:		400 WT. 1131 LBS.	
SERIAL NO.			
36-HD-400-W		REV. 11-11-09	
FOR: HANSON STANDARD		DATE: 4-1-87	
HORIZ. AIR TANK			
INSIDE: UNPAINTED			
OUTSIDE: PRIME			
CAD-"B" SIZE UNDER "STD"-SERIES			
BY: J.G.		SCALE: 3/4"=12"	
ROY E. HANSON JR. MFG.			
1600 E. WASHINGTON BLVD.			
LOS ANGELES, CA 90021			